

# ROTARY POTENTIOMETERS

## 16mm Size Snap-in Insulated Shaft Potentiometers

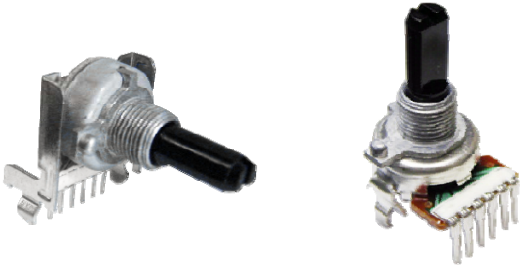

### ◆ FEATURE

- Ideal for all types of audio products.

### ◆ APPLICATIONS

- Ideal for radio, cassette recorder with Radio, amplifier, receiver, etc.

### ◆ PRODUCTS NUMBERING SYSTEM

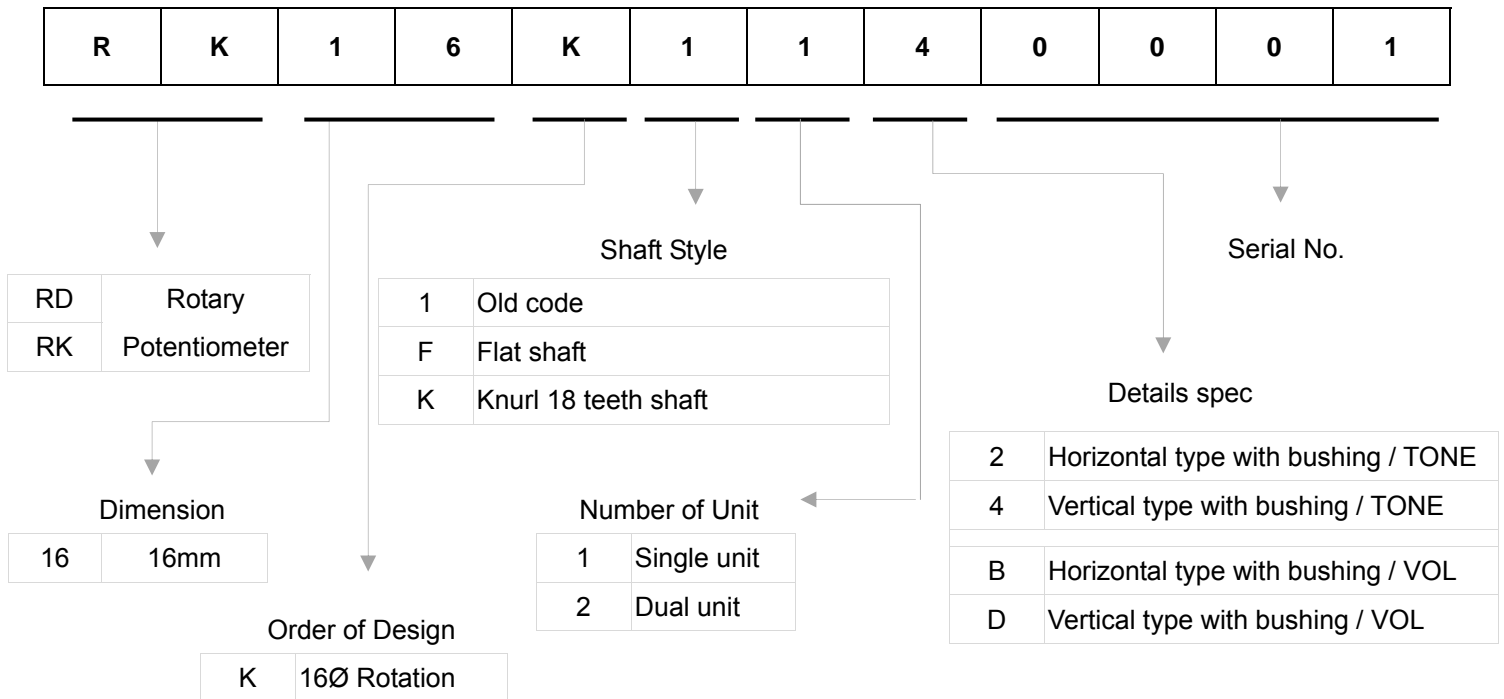

### ◆ COMMON SPECIFICATIONS

Application	16mm size	
	Single-unit	Dual-unit
Total resistance (KΩ)	5、10、20、50、100、250、500	
Total resistance Tolerance	±20%	
Resistance taper	A、B、C、D、E、W	A、B、C、D、E、M、N、W
Power rating	B Taper 0.1W the others 0.05W	0.05W
Max operating Voltage	50V A.C 20V D.C	50V A.C For A.C only
Rotational angle	300±5°	
rating torque	20~200gf-cm	30~200gf-cm
Bushing nut tightening strength	10Kgf-cm min.	
Rotational Life	15,000 cycles	

# ROTARY POTENTIOMETERS

## 16mm Size Snap-in Insulated Shaft Potentiometers

### ◆ PRODUCTS LINE

Size (mm)	Type	Type	Model	Bushing	Center Detent	Center Tap	Mounting Height (mm)	Applications
16	Single unit	Horizontal	RK16K112	✓	✓	—	12.5	General Purpose
		Vertical	RK16K114	✓	✓	—		
	Dual unit	Horizontal	RK16K122	✓	✓	—	12.5	Tone control
		Vertical	RK16K124	✓	✓	—		
	Dual unit	Horizontal	RK16K12B	✓	✓	—	12.5	Volume control
		Vertical	RK16K12D	✓	✓	—		

### ◆ STANDARD DIMENSION OF SHAFT AND BUSHING

Unit : mm



Flat Type						Knurled Type																	
Horizontal			Vertical			Horizontal			Vertical														
L1	L2	LB	L1	L2	LB	L1	L2	LB	L1	L2	LB	L1	L2	LB									
18	12	5	18	12	5	18	12	5	18	12	5	18	12	5									
23	12	5	23	12	5	23	12	5	23	12	5	23	12	5									
28	12	5	28	12	5	28	12	5	28	12	5	28	12	5									
20	12	7	20	12	7	20	12	7	20	12	7	20	12	7									
25	12	7	25	12	7	25	12	7	25	12	7	25	12	7									
30	12	7	30	12	7	30	12	7	30	12	7	30	12	7									

# ROTARY POTENTIOMETERS

## 16mm Size Snap-in Insulated Shaft Potentiometers

### DIMENSIONS

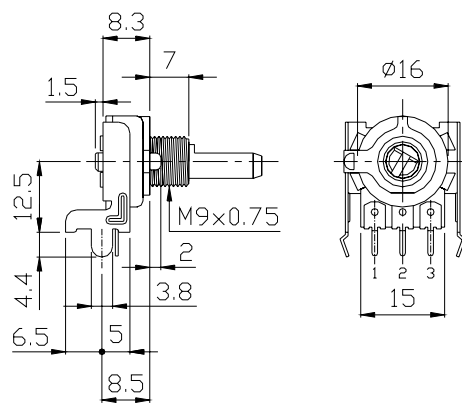
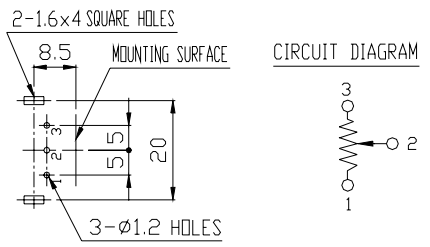
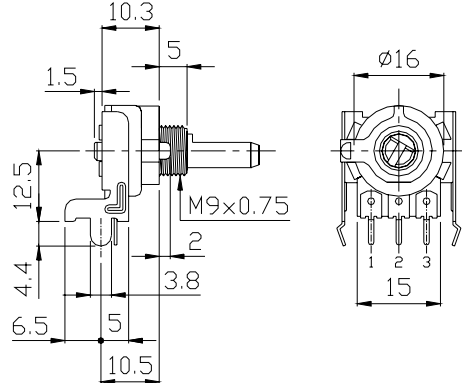
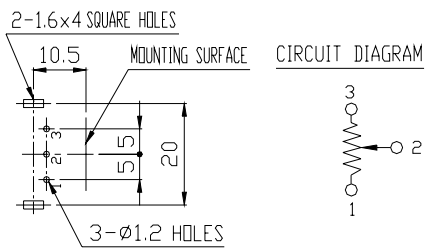
Unit : mm

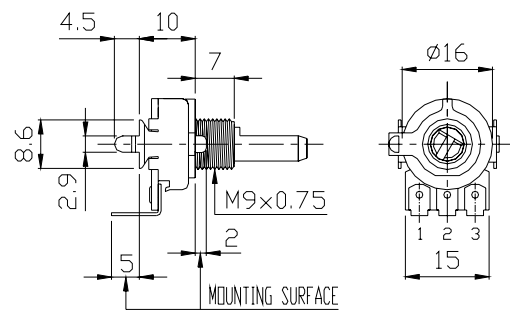
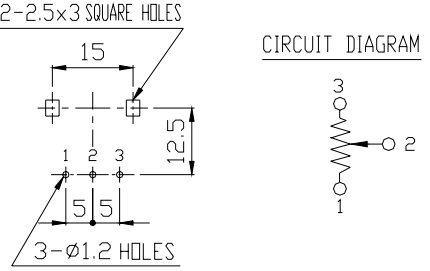
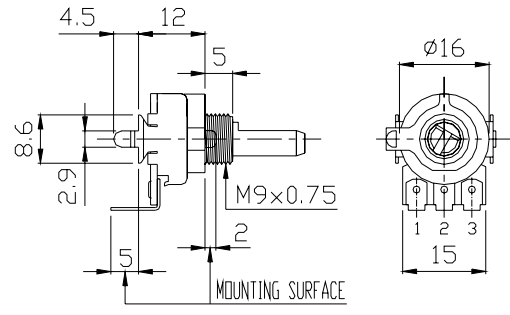
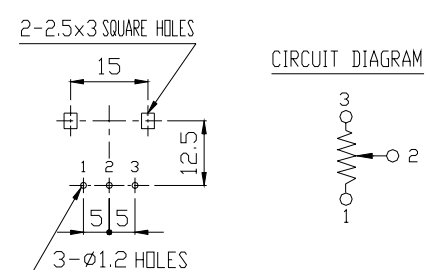



Model	Dimensions	Mounting hole details
		
		
		
		

# ROTARY POTENTIOMETERS

## 16mm Size Snap-in Insulated Shaft Potentiometers

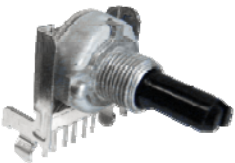
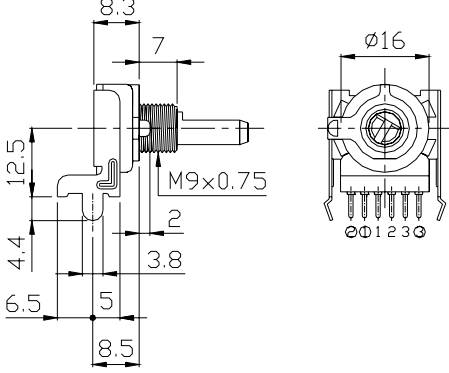
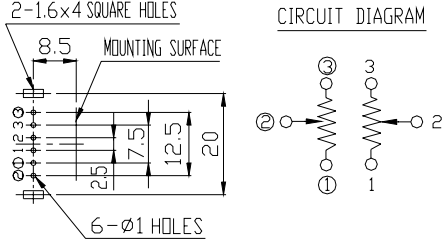
### DIMENSIONS

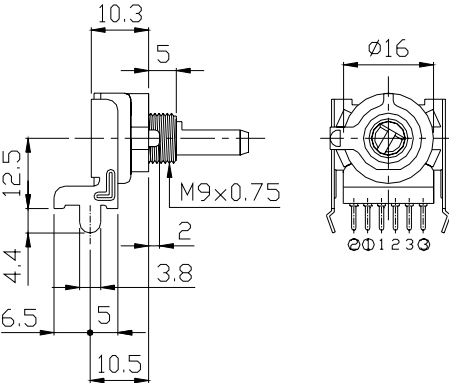
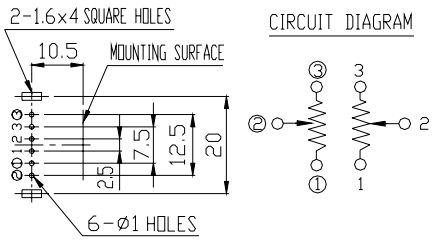
Unit : mm

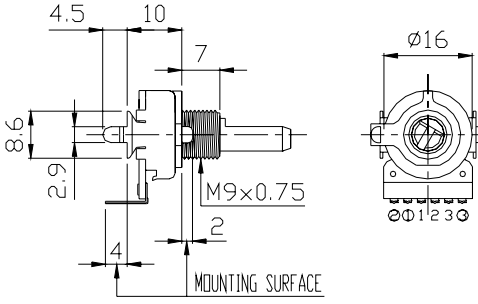
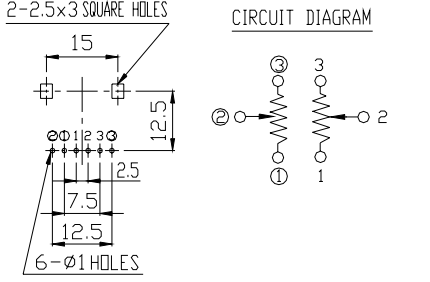
Model	Dimensions	Mounting hole details
<p>RK16K122 RK16K12B</p> 		
<p>RK16K124 RK16K12D</p> 		
<p>RK16K124 RK16K12D</p> 		
<p>RK16K124 RK16K12D</p> 