

# Blore Edwards Rotary Wafer Switches – PX

*We're in control*

## General characteristics of TYPE PX

The Type PX Rotary Wafer Switch has 23.8mm diameter moulded wafers and is available as a 30° indexing switch. Using a coiled spring mechanism the PX is available as a single or double-armed switch with three varying torque index springs. With spindle diameters available at 4mm, 6mm and 6.35mm and bushes with varying lengths in both imperial and metric threads, the TYPE PX is a neat and robust miniature rotary wafer switch with a minimum switching life of 20,000 cycles.

## Electrical Specification

Maximum working voltage 300V ac (rms) or dc

Contact rating

Current Carrying	2 Amp Continuous
Current Breaking with resistive load	25 Watt ac or 15 Watt dc Recommended max voltage 300V ac and max current 500mA ac, dc
Proof voltage	1000V ac (rms) minimum
Insulation resistance (all paths)	Greater than 10 <sup>6</sup> Megohms
Contact resistance (initial)	2 – 10 Milliohms
(After 20,000 cycles)	Not greater than 5 milliohms above initial

## Mechanical Specification

End Stop Strength 1.7Nm (15lb ins)

Maximum switching per wafer

Poles	1	2	3	4	5	6	7	
Ways	12	9	5	4	3	2	2	30° Indexing

## Contacts

Standard – Brass silver plated, silver alloy or brass gold plated contacts are available  
PC Terminations – available in above finishes  
PC Pin and standard terminations

## Rotor Blades

Make before break or break before make, all available in above finishes

## Insulation

Stator – Moulded diallylphtalate (DAP)  
Rotor – Acetal resin

## Finish

Standard – Zinc plated and passivated. Other finishes available on request

## TYPE PX

Dimensions in millimetres

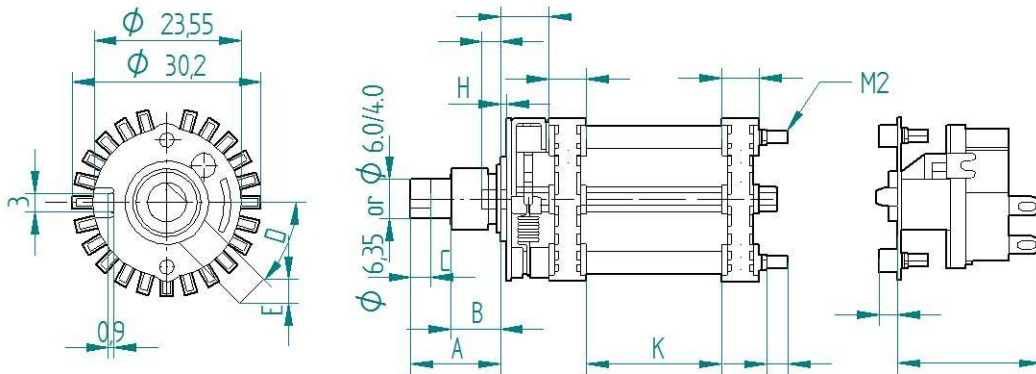

### Key to Details

- A. Shaft length to specification
- B. Bushing thread length. Imp. 9.5 or Metric 8.0,10.0 or 12.0mm
- C. Flat length to specification. Special flat trims may be provided to special requirement
- D. Angle of flat to specification  $\pm 2^\circ$ . Specify position of flat with switch in fully anti-clockwise position when viewed from knob end.
- E. Flat thickness to spec. standard 5.54  $\pm 0.05$
- F. Distance of locating key centre line to centre line of shaft.
- H. Bushing shoulder: Type PX 1.8mm standard version
- J. Type PX 8.5 minimum unsealed, fixed stop standard version.
- K. Wafers are self-stacking. Spacing between wafers can be provided in 1mm increments.
- L. If no spacer 2.7 spacers may be inserted at this point in 1mm increments.
- M. As required.
- P. Locating lug lengths 0.81 zero position only

### Optional features

Concentric shafts – dual concentric mechanisms, panel and spindle seals, bushes other than specified available to special order, printed circuit terminations, adjustable stop, electrostatic screens and facilities for fitting mains switches, potentiometers and potentiometers with mains switches.

Note:- Spindle/panel sealing available only with 3/8" dia x 3/8" long bush.